



MODEL W1681 BUFFING ASSEMBLY



OWNER'S MANUAL

Phone: (360) 734-3482 • Online Technical Support: tech-support@shopfox.biz

COPYRIGHT © AUGUST, 2001 BY WOODSTOCK INTERNATIONAL, INC. REVISED MAY, 2013 (ST)

WARNING: NO PORTION OF THIS MANUAL MAY BE REPRODUCED IN ANY SHAPE OR FORM WITHOUT

THE WRITTEN APPROVAL OF WOODSTOCK INTERNATIONAL, INC.



WARNING!

This manual provides critical safety instructions on the proper setup, operation, maintenance, and service of this machine/tool. Save this document, refer to it often, and use it to instruct other operators.

Failure to read, understand and follow the instructions in this manual may result in fire or serious personal injury—including amputation, electrocution, or death.

The owner of this machine/tool is solely responsible for its safe use. This responsibility includes but is not limited to proper installation in a safe environment, personnel training and usage authorization, proper inspection and maintenance, manual availability and comprehension, application of safety devices, cutting/sanding/grinding tool integrity, and the usage of personal protective equipment.

The manufacturer will not be held liable for injury or property damage from negligence, improper training, machine modifications or misuse.



WARNING!

Some dust created by power sanding, sawing, grinding, drilling, and other construction activities contains chemicals known to the State of California to cause cancer, birth defects or other reproductive harm. Some examples of these chemicals are:

- Lead from lead-based paints.
- Crystalline silica from bricks, cement and other masonry products.
- Arsenic and chromium from chemically-treated lumber.

Your risk from these exposures varies, depending on how often you do this type of work. To reduce your exposure to these chemicals: Work in a well ventilated area, and work with approved safety equipment, such as those dust masks that are specially designed to filter out microscopic particles.

Contents

INTRODUCTION 2
 Woodstock Technical Support 2

SAFETY..... 3
 Standard Machinery Safety 3
 Additional Safety for Buffing Assemblies 5

SETUP 6
 Unpacking 6
 Inventory 6
 Cleaning Machine..... 6
 Choosing a Motor 7
 Configuring Pulleys 7
 Mounting..... 8

OPERATIONS 10
 General 10
 Testing 10
 Buffing/Polishing 11

MAINTENANCE 12
 General 12
 Cleaning 12
 Lubrication 12

SERVICE 13
 Troubleshooting..... 13

PARTS 14

WARRANTY 17

USE THE QUICK GUIDE PAGE LABELS TO SEARCH OUT INFORMATION FAST!



INTRODUCTION

Woodstock Technical Support

This machine has been specially designed to provide many years of trouble-free service. Close attention to detail, ruggedly built parts and a rigid quality control program assure safe and reliable operation.

Woodstock International, Inc. is committed to customer satisfaction. Our intent with this manual is to include the basic information for safety, setup, operation, maintenance, and service of this product.

We stand behind our machines! In the event that questions arise about your machine, please contact Woodstock International Technical Support at (360) 734-3482 or send e-mail to: tech-support@shopfox.biz. Our knowledgeable staff will help you troubleshoot problems and process warranty claims.

If you need the latest edition of this manual, you can download it from <http://www.shopfox.biz>.

If you have comments about this manual, please contact us at:

Woodstock International, Inc.
Attn: Technical Documentation Manager
P.O. Box 2309
Bellingham, WA 98227
Email: manuals@woodstockint.com

SAFETY

**READ MANUAL BEFORE OPERATING MACHINE.
FAILURE TO FOLLOW INSTRUCTIONS BELOW WILL
RESULT IN PERSONAL INJURY.**



Indicates an imminently hazardous situation which, if not avoided, WILL result in death or serious injury.



Indicates a potentially hazardous situation which, if not avoided, COULD result in death or serious injury.



Indicates a potentially hazardous situation which, if not avoided, MAY result in minor or moderate injury.

NOTICE

This symbol is used to alert the user to useful information about proper operation of the equipment, and/or a situation that may cause damage to the machinery.

Standard Safety Instructions

1. **READ THROUGH THE ENTIRE MANUAL BEFORE STARTING MACHINERY.** Machinery presents serious injury hazards to untrained users.
2. **ALWAYS USE ANSI APPROVED SAFETY GLASSES WHEN OPERATING MACHINERY.** Everyday eye-glasses only have impact resistant lenses—they are NOT safety glasses.
3. **ALWAYS WEAR A NIOSH APPROVED RESPIRATOR WHEN OPERATING MACHINERY THAT PRODUCES DUST.** Wood dust is a carcinogen and can cause cancer and severe respiratory illnesses.
4. **ALWAYS USE HEARING PROTECTION WHEN OPERATING MACHINERY.** Machinery noise can cause permanent hearing damage.
5. **WEAR PROPER APPAREL.** DO NOT wear loose clothing, gloves, neckties, rings, or jewelry which may get caught in moving parts. Wear protective hair covering to contain long hair and wear non-slip footwear.
6. **NEVER OPERATE MACHINERY WHEN TIRED, OR UNDER THE INFLUENCE OF DRUGS OR ALCOHOL.** Be mentally alert at all times when running machinery.
7. **ONLY ALLOW TRAINED AND PROPERLY SUPERVISED PERSONNEL TO OPERATE MACHINERY.** Make sure operation instructions are safe and clearly understood.
8. **KEEP CHILDREN AND VISITORS AWAY.** Keep all children and visitors a safe distance from the work area.
9. **MAKE WORKSHOP CHILD PROOF.** Use padlocks, master switches, and remove start switch keys.

10. **NEVER LEAVE WHEN MACHINE IS RUNNING.** Turn power **OFF** and allow all moving parts to come to a complete stop before leaving machine unattended.
11. **DO NOT USE IN DANGEROUS ENVIRONMENTS.** DO NOT use machinery in damp, wet locations, or where any flammable or noxious fumes may exist.
12. **KEEP WORK AREA CLEAN AND WELL LIT.** Clutter and dark shadows may cause accidents.
13. **USE A GROUNDED EXTENSION CORD RATED FOR THE MACHINE AMPERAGE.** Undersized cords overheat and lose power. Replace extension cords if they become damaged. DO NOT use extension cords for 220V machinery.
14. **ALWAYS DISCONNECT FROM POWER SOURCE BEFORE SERVICING MACHINERY.** Make sure switch is in OFF position before reconnecting.
15. **MAINTAIN MACHINERY WITH CARE.** Keep blades sharp and clean for best and safest performance. Follow instructions for lubricating and changing accessories.
16. **MAKE SURE GUARDS ARE IN PLACE AND WORK CORRECTLY BEFORE USING MACHINERY.**
17. **REMOVE ADJUSTING KEYS AND WRENCHES.** Make a habit of checking for keys and adjusting wrenches before turning machinery **ON**.
18. **CHECK FOR DAMAGED PARTS BEFORE USING MACHINERY.** Check for binding and alignment of parts, broken parts, part mounting, loose bolts, and any other conditions that may affect machine operation. Repair or replace damaged parts.
19. **USE RECOMMENDED ACCESSORIES.** Refer to the instruction manual for recommended accessories. The use of improper accessories may cause risk of injury.
20. **DO NOT FORCE MACHINERY.** Work at the speed for which the machine or accessory was designed.
21. **SECURE WORKPIECE.** Use clamps or a vise to hold the workpiece when practical. A secured workpiece protects your hands and frees both hands to operate the machine.
22. **DO NOT OVERREACH.** Keep proper footing and balance at all times.
23. **MANY MACHINES WILL EJECT THE WORKPIECE TOWARD THE OPERATOR.** Know and avoid conditions that cause the workpiece to "kickback."
24. **ALWAYS LOCK MOBILE BASES (IF USED) BEFORE OPERATING MACHINERY.**
25. **BE AWARE THAT CERTAIN DUST MAY BE HAZARDOUS** to the respiratory systems of people and animals, especially fine dust. Make sure you know the hazards associated with the type of dust you will be exposed to and always wear a respirator approved for that type of dust.

Additional Safety for Buffing Assemblies

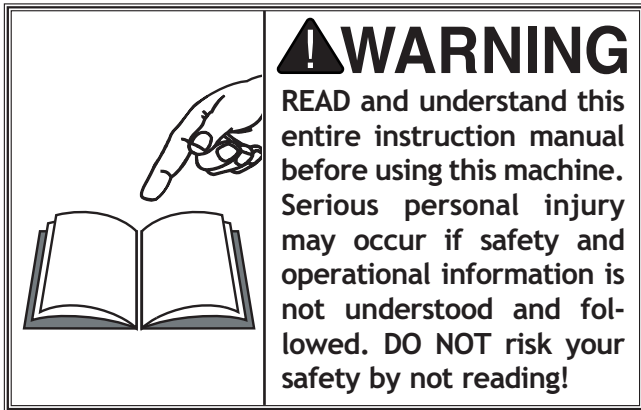

1. Always wear a face shield and/or safety goggles.
2. Secure this buffer firmly to a benchtop or stand.
3. Never use a grinding wheel on this machine. It is strictly designed for buffing and polishing only.
4. Do not stand directly in front of buffing accessories when turning the machine on.
5. Do not jam work against the buffing wheel. Slowly ease the work into the buffing wheel.
6. Allow the wheel to attain full speed before introducing the workpiece.
7. Do not allow your hands to come into contact with the buffing wheel. Abrasive accessories are designed to remove material very quickly.
8. Never perform any adjustment or maintenance procedure while the motor is plugged in.
9. Never leave the machine running unattended.
10. Never attempt to buff small parts. If you cannot hold small parts securely, do not buff them with this machine. Secure them with clamps or similar jigs.
11. Buffing can produce large amounts of dust. Be sure to wear the appropriate dust mask to prevent the breathing of harmful particles. Be sure to follow the recommended use of the specific dust mask you are using.
12. Be aware of maximum speeds for the buffing wheels. Never exceed the maximum speed listed on each buffing/polishing wheel.

SETUP

Unpacking

This machine has been carefully packaged for safe transportation. If you notice the machine has been damaged during shipping, please contact your authorized Shop Fox dealer immediately.

Inventory

The following is a description of the main components shipped with the Model W1681. Lay the components out to inventory them.

Note: *If you can't find an item on this list, check the mounting location on the machine or examine the packaging materials carefully. Occasionally we pre-install certain components for safer shipping.*

Box Inventory	Qty
A. Buffing Assembly*.....	1
B. V-Belt.....	1
C. Wheel Flanges.....	4
D. Arbor Nuts.....	4

**Motor and motor pulley are not included.*

Cleaning Machine

The shafts of your buffer are coated with a waxy grease that protects them from corrosion during shipment. Clean this grease off with a solvent cleaner or citrus-based degreaser. **DO NOT** use chlorine-based solvents such as brake parts cleaner or acetone—if you happen to splash some onto a painted surface, you will ruin the finish.

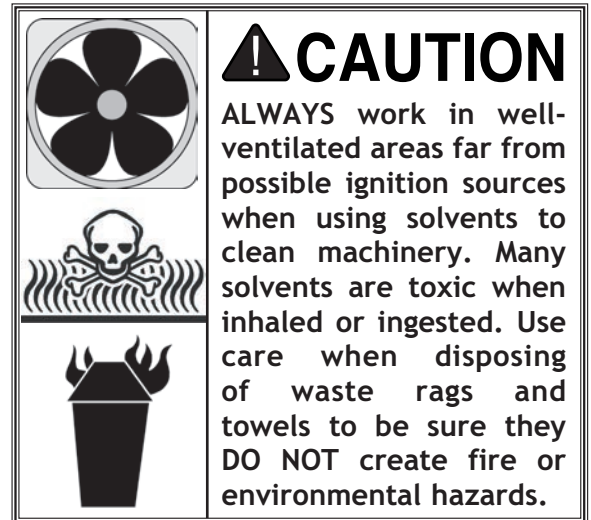
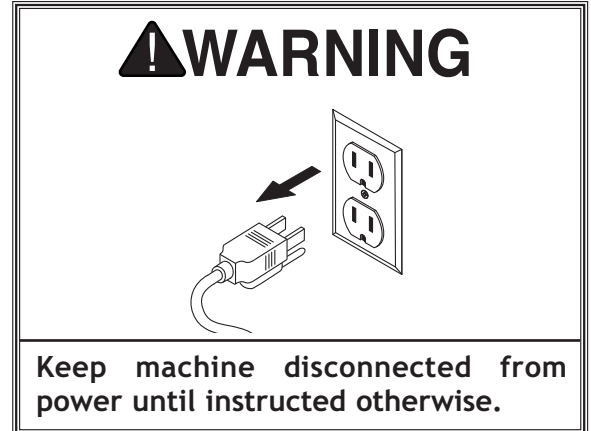

SETUP

Choosing a Motor

The Shop Fox® W1681 does not come with a motor or electrical package. We recommend using a 1725 RPM, 1/3 H.P. or larger motor.

Always follow the motor manufacturer's electrical requirements for the motor that you install.

Configuring Pulleys

The buffing assembly comes with a three step arbor pulley. The three progressive diameters are 2", 3" and 4". We recommend using a 1" motor shaft pulley and a 1725 RPM motor for the easiest set up of buffing wheel speeds.

The arbor should never rotate faster than 1725 RPM. When using a 2" pulley on a 1725 RPM motor, in conjunction with the 2" step on the arbor pulley, you will achieve a buffing wheel speed of 1725 RPM. As you move the V-belt to progressively larger pulley steps, the buffing wheel RPM will drop. Never use a pulley configuration that uses a motor pulley that is larger in diameter than the arbor pulley. See the diagram in **Figure 1**.

⚠ WARNING

Never use a pulley configuration that uses a motor pulley that is larger in diameter than the arbor pulley. This will result in an arbor RPM that is greater than 1725 RPM. An arbor RPM greater than 1725 RPM is not recommended.

SETUP

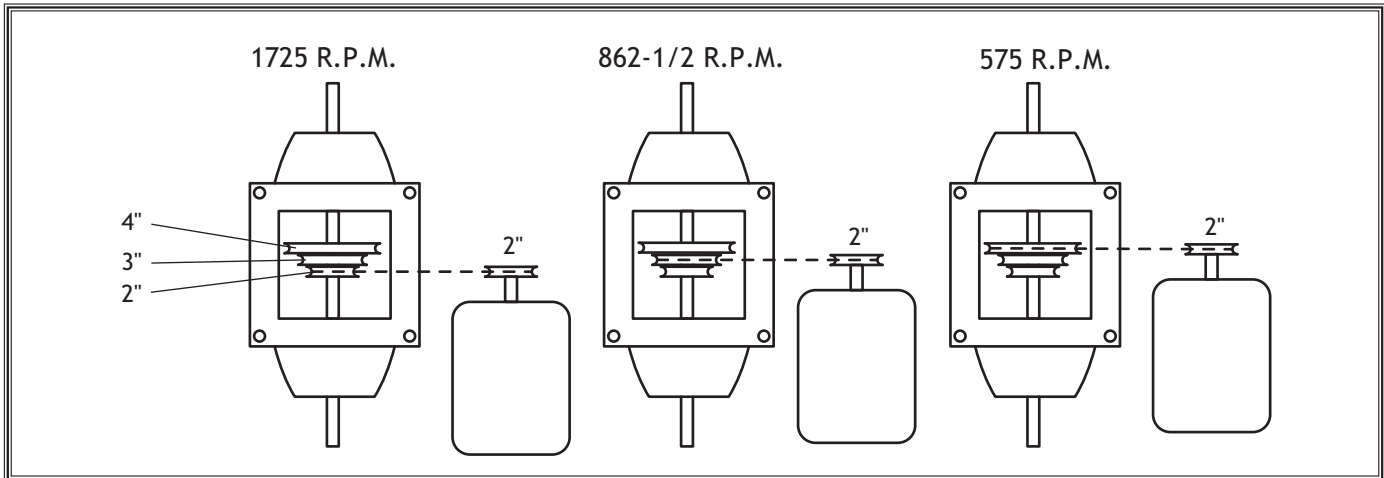

Figure 1. Pulley alignment for each speed.

Mounting

The strongest bench mounting option is a "Through Mount" where holes are drilled all the way through the workbench, and hex bolts, washers, and hex nuts are used to secure the drill press to the workbench.

Another option for mounting is a "Direct Mount" where the machine is simply secured to the workbench with a lag screw.

The Model W1681 is designed to mount to a bench top using (4) $\frac{5}{16}$ " diameter lag bolts or through bolts, as shown in **Figures 2 & 3**.

The motor must be mounted either directly below or behind the Buffing assembly. If the motor is mounted below the buffing assembly, a hole must be cut in the bench to allow passage of the V-belt between the buffing assembly and the motor. If the motor is mounted behind the buffing assembly, no hole in the bench is needed because the V-belt will connect to the motor through the rear casting of the buffing assembly body.

The buffing assembly must be attached to a stable workbench capable of handling the rigors of a motor driven machine. Determine if you will be mounting the motor below or behind the buffing assembly.

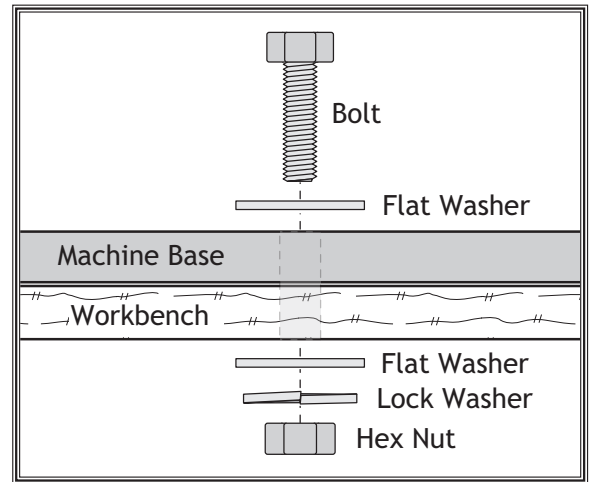

Figure 2. Example of a through mount.

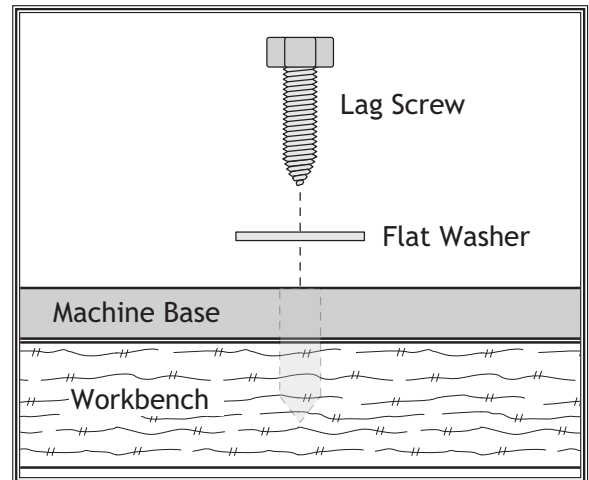

Figure 3. Example of a direct mount.

Motor Below

1. Position the buffing assembly on the workbench in the desired position. Mark the four mounting hole locations onto the workbench, as shown in **Figure 4**.
2. Trace around the open area on the inside, bottom edge of the buffing assembly. This will be the hole for the V-belt passage to the motor mount beneath.
3. Remove the buffing assembly from the workbench. Using a jig saw and drill, cut out the V-belt passage hole and drill the mounting holes into the workbench.
4. Place the buffing assembly over the mounting holes in the workbench. Using (4) $\frac{5}{16}$ " diameter lag bolts or through bolts, attach the buffing assembly to the workbench, making sure that it is secure.

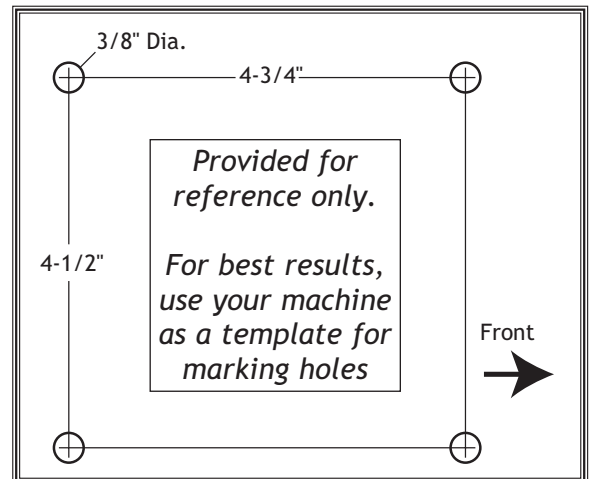

Figure 4. Mounting bolt layout.

SETUP

5. Mount the motor on a 1/2" plywood platform below the buffing assembly so that the motor pulley is directly beneath the arbor pulley. Be sure to orient the motor rotation so the buffing wheels will be rotating downward on the working side of the buffing assembly. Attach the platform to the workbench using a piano hinge, as shown in **Figure 5**.
6. Install the V-belt on the desired pulleys.

Motor Behind

1. Position the buffing assembly on the workbench in the desired position. Mark the four mounting hole locations onto the workbench.
2. Remove the buffing assembly from the workbench and set aside.
3. Using a drill, drill the mounting holes into the workbench.
4. Place the buffing assembly over the mounting holes in the workbench. Using (4) 5/16" diameter lag bolts or through bolts, attach the buffing assembly to the workbench, making sure that it is secure.
5. Mount the motor on a 1/2" plywood platform and attach to the back of the workbench with a piano hinge as shown in **Figure 6**. Be sure to orient the motor rotation so the buffing wheels will be rotating downward on the working side of the buffing assembly. Attach the motor so the motor pulley is in-line with the arbor pulley.
6. Install the V-belt on the desired pulleys.
7. We recommend building a plywood guard to cover the V-belt and motor pulley assembly. This will prevent the operator from accidentally coming into contact with the belt during operation.

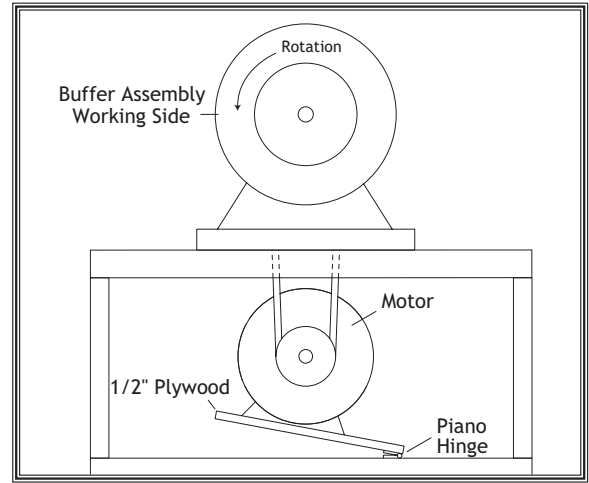

Figure 5. Motor and buffer assembly locations.

⚠ WARNING

Be sure to mount the motor so the rotation of the buffing wheels is downward on the working side of the assembly. If the buffing wheels rotate upward on the working side, the object being worked on could be propelled up and into the path of the operator causing serious personal injury.

SETUP

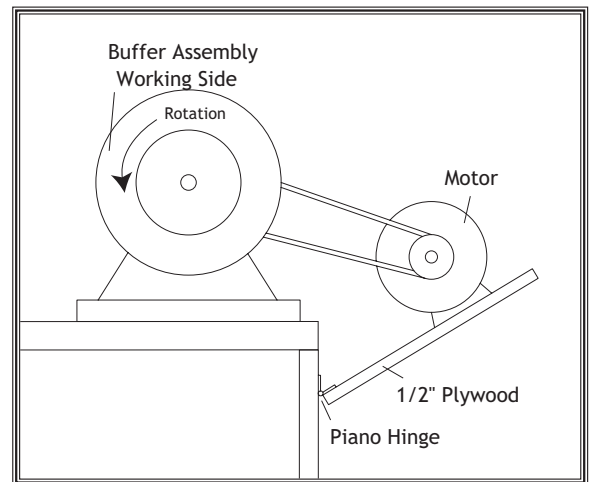

Figure 6. Side view of motor mounting behind.

OPERATIONS

General

This machine will perform many types of operations that are beyond the scope of this manual. Many of these operations can be dangerous or deadly if performed incorrectly.

The instructions in this section are written with the understanding that the operator has the necessary knowledge and skills to operate this machine. **If at any time you are experiencing difficulties performing any operation, stop using the machine!**

If you are an inexperienced operator, we strongly recommend that you read books, trade articles, or seek training from an experienced *buffer* operator before performing any unfamiliar operations. **Above all, your safety should come first!**

Testing

Once assembly is complete and adjustments have been made, the machine is ready for a test run. The purpose of a test run is to identify any unusual noises and vibrations, as well as to confirm the machine is performing as intended.

To test run your buffer setup, do these steps:

1. Turn the machine **ON** by pressing the START button on the power switch. Be sure to have your finger poised to hit the STOP button if there is a problem.
2. Once the machine is running, listen for any unusual noises. The machine should run smoothly with little or no vibrations.
3. If there are any unusual noises or vibrations, shut the machine **OFF** immediately. The machine should not be run any further until the problems are corrected.
4. Unplug the machine and investigate the source of the noise or vibration. Do not make any adjustments to the machine while it is plugged in.
5. Repeat **Steps 1-4** until machine runs smoothly.

WARNING



READ and understand this entire instruction manual before using this machine. Serious personal injury may occur if safety and operational information is not understood and followed. **DO NOT** risk your safety by not reading!

WARNING

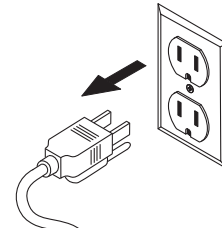

DO NOT investigate problems or adjust the machine while it is running. Wait until the machine is turned **OFF**, unplugged and all working parts have come to a complete stop before proceeding!

WARNING



Always wear safety glasses when operating this machine. Failure to comply may result in serious personal injury.

Buffing/Polishing

The Model W1681 buffing assembly is a simple and straightforward machine to use. There are many different styles of discs and compounds to choose from. It is very important that you do not use grinding wheels on this machine. The buffing assembly is designed exclusively for buffing and polishing only.

To use your buffing assembly, do these steps:

1. Select the $\frac{3}{4}$ " buffing wheels that you want to install on the machine.
2. Loosen the arbor nuts located on each end of the arbor. The left hand end of the arbor has left hand threads and the right hand end of the arbor has right hand threads.
3. Sandwich each buffing wheel between the wheel flanges, making certain the convex side of the washer faces away from the body of the buffing wheels. Use only the wheel flanges supplied with the machine.
4. Slide the buffing wheel assemblies onto each end of the arbors and securely tighten each of the arbor nuts, as shown in **Figure 7**.
5. Turn the buffing assembly **ON** and apply the desired buffing compound to the rotating edge of the wheels. Be sure to wear safety glasses and dust mask, as compound often flies off during application and operation.
6. Follow these tips while buffing your workpiece:
 - Thoroughly clean all parts that you plan to buff. Any kind of dirt, oil, rust, paint or other film must be removed either chemically or sprayed off with water. Make sure to dry off parts with a rag after cleaning.
 - Only use the area indicated in **Figure 8** to do the actual buffing. Contacting the workpiece on areas outside the correct area may flip the workpiece out of your hands.
 - Hold the workpiece tightly at all times while buffing. Placing one hand near the contact point will give you better control.

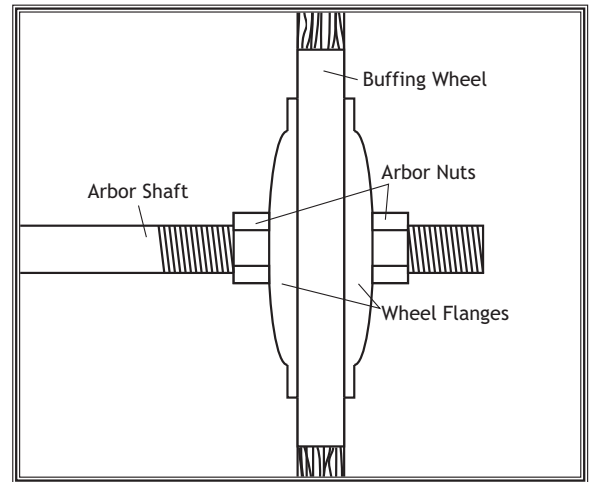

Figure 7. Buffing wheel assembled on arbor.

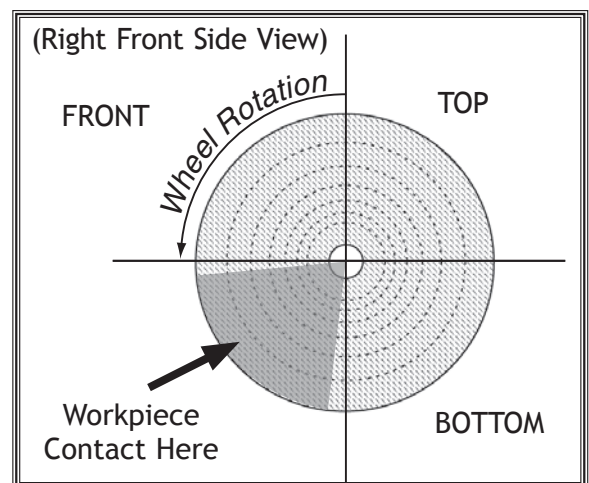

Figure 8. Location where workpiece should contact wheel.

MAINTENANCE

General

Regular periodic maintenance on your machine will ensure its optimum performance. Make a habit of inspecting your machine each time you use it.

Check for the following conditions and repair or replace when necessary:

- Loose mounting bolts.
- Worn switch.
- Worn or damaged cords and plugs.
- Damaged V-belt.
- Any other condition that could hamper the safe operation of this machine.

⚠ WARNING

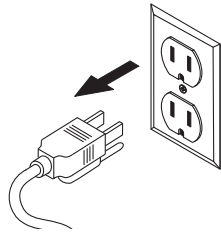

MAKE SURE that your machine is unplugged during all maintenance procedures! If this warning is ignored, serious personal injury may occur.

Cleaning

Frequently vacuum dust off of the buffer and motor. This is especially important for the internal working parts and motor. Dust build-up around the motor is a sure way to decrease its lifespan.

Lubrication

Since all bearings are sealed and permanently lubricated, simply leave them alone until they need to be replaced. Do not lubricate them.

SERVICE

Troubleshooting

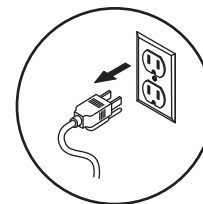

This section covers the most common problems and corrections with this type of machine. **WARNING! DO NOT** make any adjustments until power is disconnected and moving parts have come to a complete stop!

PROBLEM	POSSIBLE CAUSE	CORRECTIVE ACTION
Machine stalls or is overloaded.	<ol style="list-style-type: none"> 1. Motor connection wired incorrectly. 2. Motor bearings are at fault. 3. Motor is at fault. 4. Buffing wheel is too large/wide or exceeds recommended wheel rating. 	<ol style="list-style-type: none"> 1. Correct motor wiring connections. 2. Test by rotating shaft; rotational grinding/loose shaft requires bearing replacement. 3. Test/repair/replace. 4. Replace with smaller wheel or reduce wheel width.
Machine has vibration or noisy operation.	<ol style="list-style-type: none"> 1. Motor or component is loose. 2. Incorrectly mounted to workbench. 3. Motor fan is rubbing on fan cover. 4. Bearings are at fault. 5. Shaft is bent. 6. Buffing wheel has become loose, worn, or components (steel center hub) are dislodged. 	<ol style="list-style-type: none"> 1. Inspect/replace stripped or damaged bolts/nuts, and re-tighten with thread locking fluid. 2. Shim or tighten mounting hardware. 3. Replace dented fan cover; replace loose/damaged fan. 4. Test by rotating shaft; rotational grinding/loose shaft requires bearing replacement. 5. Test with dial indicator and replace if necessary. 6. Replace buffing wheel.

PARTS

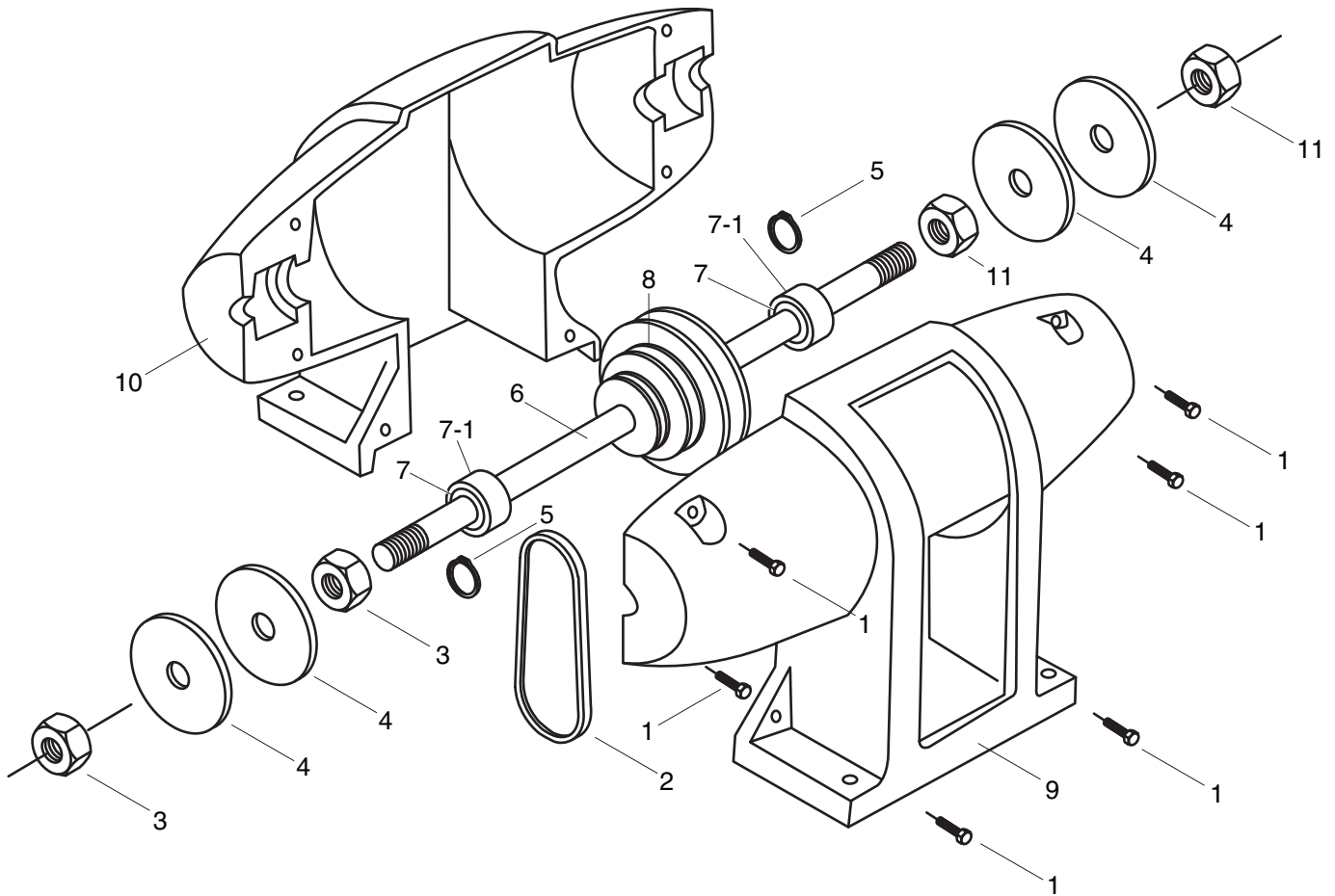

REF	PART #	DESCRIPTION
01	X1681001	HEX HEAD BOLT
02	X1681002	V-BELT 4L280
03	X1681003	RIGHT HAND ARBOR NUT
04	X1681004	3" PLEATED FLANGES $\frac{3}{4}$ " ID
05	X1681005	RETAINING RING
06	X1681006	ARBOR SHAFT
07	X1681007	BALL BEARING
07-1	X1681007-1	RUBBER BEARING COVER
08	X1681008	ARBOR PULLEY
09	X1681009	REAR CAST HOUSING
10	X1681010	FRONT CAST HOUSING
11	X1681011	LEFT HAND ARBOR NUT



Warranty Registration

Name _____
 Street _____
 City _____ State _____ Zip _____
 Phone # _____ Email _____ Invoice # _____
 Model # _____ Serial # _____ Dealer Name _____ Purchase Date _____

The following information is given on a voluntary basis. It will be used for marketing purposes to help us develop better products and services. **Of course, all information is strictly confidential.**

- How did you learn about us?

<input type="checkbox"/> Advertisement	<input type="checkbox"/> Friend	<input type="checkbox"/> Local Store
<input type="checkbox"/> Mail Order Catalog	<input type="checkbox"/> Website	<input type="checkbox"/> Other:
- How long have you been a woodworker/metalworker?

<input type="checkbox"/> 0-2 Years	<input type="checkbox"/> 2-8 Years	<input type="checkbox"/> 8-20 Years	<input type="checkbox"/> 20+ Years
------------------------------------	------------------------------------	-------------------------------------	------------------------------------
- How many of your machines or tools are Shop Fox?

<input type="checkbox"/> 0-2	<input type="checkbox"/> 3-5	<input type="checkbox"/> 6-9	<input type="checkbox"/> 10+
------------------------------	------------------------------	------------------------------	------------------------------
- Do you think your machine represents a good value? Yes No
- Would you recommend Shop Fox products to a friend? Yes No
- What is your age group?

<input type="checkbox"/> 20-29	<input type="checkbox"/> 30-39	<input type="checkbox"/> 40-49
<input type="checkbox"/> 50-59	<input type="checkbox"/> 60-69	<input type="checkbox"/> 70+
- What is your annual household income?

<input type="checkbox"/> \$20,000-\$29,000	<input type="checkbox"/> \$30,000-\$39,000	<input type="checkbox"/> \$40,000-\$49,000
<input type="checkbox"/> \$50,000-\$59,000	<input type="checkbox"/> \$60,000-\$69,000	<input type="checkbox"/> \$70,000+
- Which of the following magazines do you subscribe to?

<input type="checkbox"/> Cabinet Maker	<input type="checkbox"/> Popular Mechanics	<input type="checkbox"/> Today's Homeowner
<input type="checkbox"/> Family Handyman	<input type="checkbox"/> Popular Science	<input type="checkbox"/> Wood
<input type="checkbox"/> Hand Loader	<input type="checkbox"/> Popular Woodworking	<input type="checkbox"/> Wooden Boat
<input type="checkbox"/> Handy	<input type="checkbox"/> Practical Homeowner	<input type="checkbox"/> Woodshop News
<input type="checkbox"/> Home Shop Machinist	<input type="checkbox"/> Precision Shooter	<input type="checkbox"/> Woodsmith
<input type="checkbox"/> Journal of Light Cont.	<input type="checkbox"/> Projects in Metal	<input type="checkbox"/> Woodwork
<input type="checkbox"/> Live Steam	<input type="checkbox"/> RC Modeler	<input type="checkbox"/> Woodworker West
<input type="checkbox"/> Model Airplane News	<input type="checkbox"/> Rifle	<input type="checkbox"/> Woodworker's Journal
<input type="checkbox"/> Modeltec	<input type="checkbox"/> Shop Notes	<input type="checkbox"/> Other:
<input type="checkbox"/> Old House Journal	<input type="checkbox"/> Shotgun News	

9. Comments: _____

CUT ALONG DOTTED LINE

FOLD ALONG DOTTED LINE

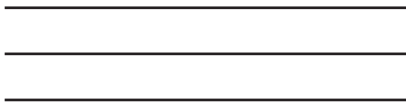

Place
Stamp
Here



WOODSTOCK INTERNATIONAL INC.
P.O. BOX 2309
BELLINGHAM, WA 98227-2309



FOLD ALONG DOTTED LINE

TAPE ALONG EDGES--PLEASE DO NOT STAPLE

WARRANTY

Woodstock International, Inc. warrants all Shop Fox machinery to be free of defects from workmanship and materials for a period of two years from the date of original purchase by the original owner. This warranty does not apply to defects due directly or indirectly to misuse, abuse, negligence or accidents, lack of maintenance, or reimbursement of third party expenses incurred.

Woodstock International, Inc. will repair or replace, at its expense and at its option, the Shop Fox machine or machine part, which in normal use has proven to be defective, provided that the original owner returns the product prepaid to a Shop Fox factory service center with proof of their purchase of the product within two years, and provides Woodstock International, Inc. reasonable opportunity to verify the alleged defect through inspection. If it is determined there is no defect, or that the defect resulted from causes not within the scope of Woodstock International Inc.'s warranty, then the original owner must bear the cost of storing and returning the product.

This is Woodstock International, Inc.'s sole written warranty and any and all warranties that may be implied by law, including any merchantability or fitness, for any particular purpose, are hereby limited to the duration of this written warranty. We do not warrant that Shop Fox machinery complies with the provisions of any law or acts. In no event shall Woodstock International, Inc.'s liability under this warranty exceed the purchase price paid for the product, and any legal actions brought against Woodstock International, Inc. shall be tried in the State of Washington, County of Whatcom. We shall in no event be liable for death, injuries to persons or property or for incidental, contingent, special or consequential damages arising from the use of our products.

Every effort has been made to ensure that all Shop Fox machinery meets high quality and durability standards. We reserve the right to change specifications at any time because of our commitment to continuously improve the quality of our products.

